



Hardware by Compo 

Seats Slide Mechanism (SSL101/102/103)

Compo seat slide mechanism is designed to extend the seat depth of sofa by a maximum of 13 inches. With the slide full extended the sofa converts to a relaxing chair or even a lay bed.

Features include:-

- Easy mounting of seat.
- No metal to metal contact.
- Robust engineering plastic slider.
- Adjustable seat depth.
- Bumps is built into the slide to prevent sliding at sitting positions.
- It will only slide when we nudge the seat forward.

As usual our seat slide is built to the exacting standard expected of compo product.









3

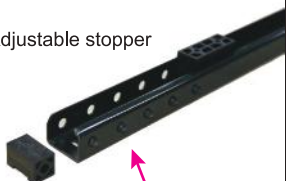

Extension Position

<p>Closed Position</p> 	<p>Open Position</p>  <ul style="list-style-type: none"> ■ Can use the sofa as an occasional bed. ■ The seat extension is long enough to support the leg for greater comfort.
---	--

Key Features

 <p>Bumps to prevent sliding at sitting position</p>	<p>Heavy duty engineering for long trouble free applicant.</p>  <p>As there is no metal to metal contact, there is no metal rubbing problem and application of grease is not necessary.</p>	<p>Adjustable stopper</p>  <p>Adjustment holes maximum extension length is 13"</p>	 <p>Slider- 4pcs Code: SMG 001</p>  <p>Stopper- 4pcs Code: SMS 001</p>  <p>Screw for stopper- 4pcs Code: JCBC M6x35</p>
---	--	--	--

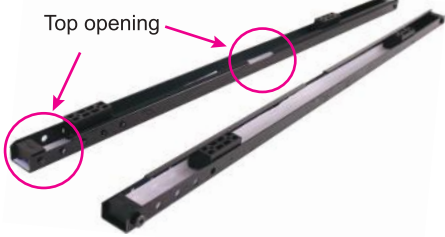
Options for seat slides mounting

<p>Seat Slide Rails - 1pair</p>  <p>SSL 101 (Front Mounting)</p>	<p>Seat Slide Rails - 1pair</p>  <p>Top opening</p> <p>SSL 102 (Top Mounting)</p>	<p>Seat Slide Rails - 1pair</p>  <p>SSL 103</p>
---	---	--

Technical Specification

Basic Dimension

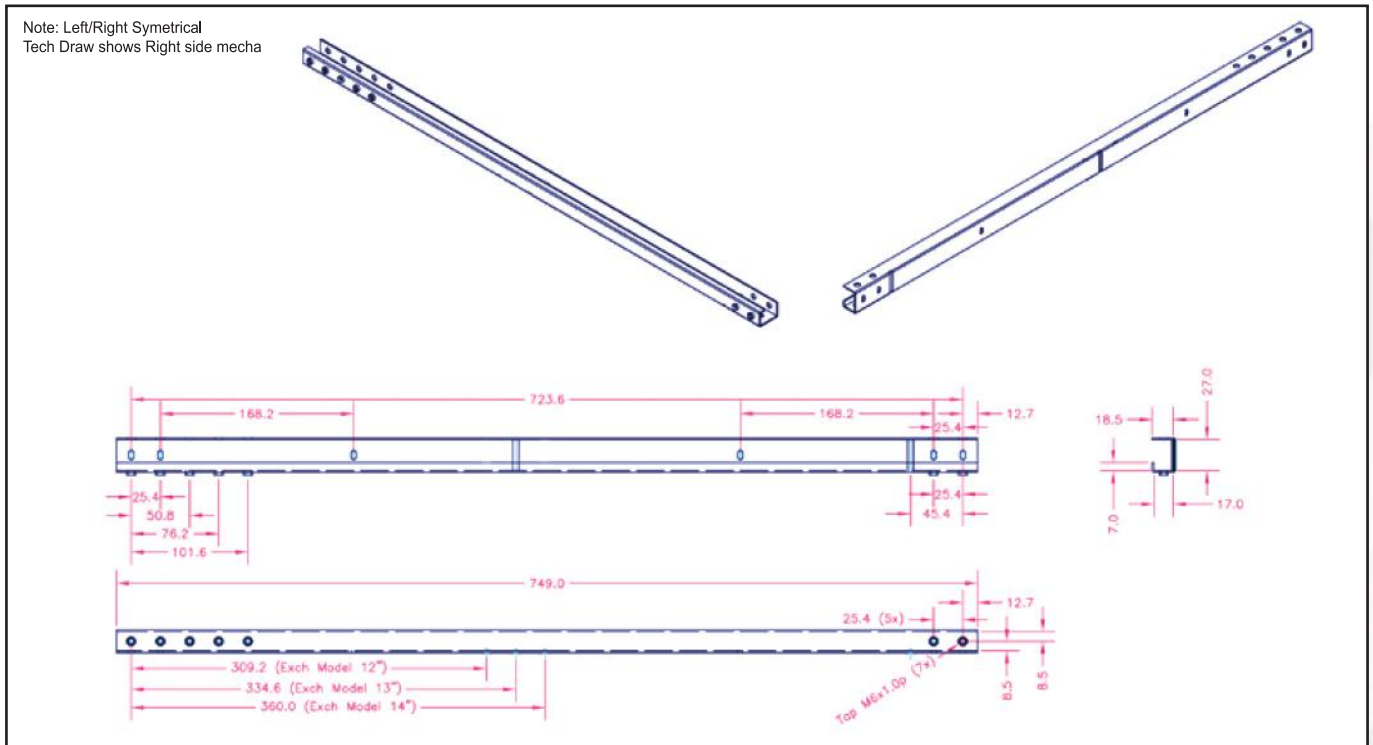

Mounting Guide

		<p>①</p> <p>Jig 1 VIEW A</p>
<p>This seat frame is designed to slide under the back frame.</p>	<p>This slider is designed to be mounted under the seat frame.</p>	<p>-Slide mecha rail (left/right) - 1 each -Chipboard screw Ø4 x 1" length-6pcs</p>
<p>②</p>	<p>③</p> <p>VIEW B</p>	<p>④</p> <p>Jig 2 VIEW C</p> <p>1. Slider Mecha Glider - 4 pcs 2. Chipboard Screw Ø4 x 1.5" Length - 8pcs</p>
<p>1. Slider Mecha Rail (Left/Right) - 1 each 2. Chipboard Screw Ø4 x 1" Length - 6 pcs 3 Use the Jig to align SM Rail Parallel</p>	<p>1. Slider Mecha Stopper - 2pcs 2. JCBB m6x35 mm Length -2pcs</p>	<p>1. Slider Mecha Glider - 4pcs 2. Chipboard Screw Ø4 x 1.5" Length - 8pcs</p>
<p>⑤</p>	<p>⑥</p>	<p>⑦</p> <p>VIEW D</p>
<p>1. Slider Mecha Glider - 4pcs 2. Chipboard Screw Ø4 x 1.5" Length - 8pcs 3. Use the Jig to position Glider in Location</p>	<p>After the slide rail slider is properly mounted, the seat form is slide into the slide rail from the front.</p>	<p>Slide the stopper into the convert stopper position and back into place using an M6 screw.</p>