

# Steel Base

We have a range of base to fulfill the requirement of various application. Our base are presently used in the making of sofas, tables and many other purpose.

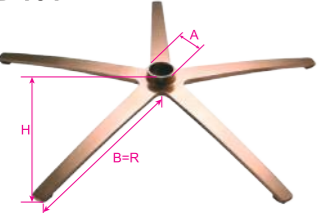
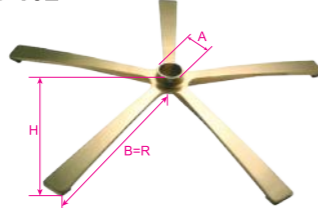
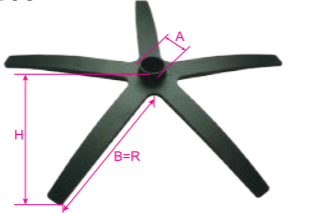

<p><b>STB 101</b></p> 	<p><b>STB 102</b></p> 	<p><b>STB 103</b></p> 
<p>Material : Iron Finishing : Red Bronze Brushed Conventional Specification : 64mm (H) Ø50mm (A) R375mm (B)</p>	<p>Material : Iron Finishing : Green Bronze Brushed Conventional Specification : 64mm (H) Ø50mm (A) R375mm (B)</p>	<p>Material : Iron Finishing : Black Sand Blasting Conventional Specification : 64mm (H) Ø50mm (A) R350mm (B)</p>

<p><b>STB 201</b></p> 	<p><b>STB 202</b></p> 	<p><b>STB 203</b></p> 
<p>Material : Stainless Steel Finishing : Brushed, Polished Conventional Specification : 190mm (H) 190x190mm (T) 700x700mm (B)</p>	<p>Material : Iron Finishing : Green Bronze Brushed Conventional Specification : 310mm (H) 227x227mm (T) 655mm (B)</p>	<p>Material : Iron Finishing : Nickel Brushed Conventional Specification : 410mm (H) 190x190mm (T) R325mm (B)</p>

<p><b>SQB 101</b></p> 	<p><b>SRB 101</b></p> 	<p><b>SRB 102</b></p> 
<p>Material : Stainless Steel Finishing : Brushed, Polished Conventional Specification : 70mm (H) Ø48.5mm (A) Ø380-Ø550mm (S)</p>	<p>Material : Stainless Steel Finishing : Brushed, Polished Conventional Specification : 70mm (H) Ø48.5mm (A) Ø300-Ø600mm (S)</p>	<p>Material : Stainless Steel Finishing : Brushed, Polished Conventional Specification : 10mm (H) Ø10mm (A) Ø150-Ø720mm (S)</p>

<p><b>SRB105</b></p> 	<p><b>RBS202-550/ RBS203-600</b></p> 	<p><b>RBC101-550/ RBC101B-600</b></p> 
<p>Material : Stainless Steel Base : Ø500mm t = 8mm Column : Ø76mm Cross Plate : 600x600mm Height : 725mm</p>	<p>Material : Stainless Steel Base : Ø550/Ø600 t = 8.5mm (tapered edge) Plate Shaft Height : 7"8"</p>	<p>Material : Chrome Base : Ø550/Ø600 t = 8.5mm (R Corner) Plate Shaft Height : 7"</p>







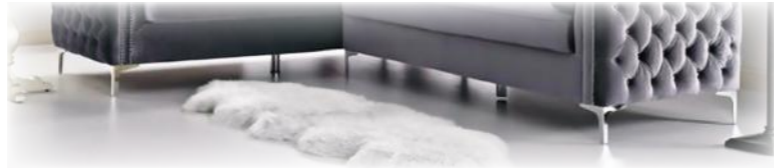







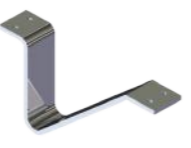



# Sofa Leg Series I



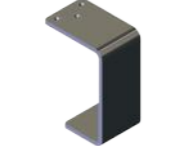
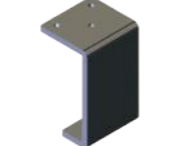





We have a range of sofa legs to fulfill the requirement of various application. Our sofa legs are presently used in the making of sofas, bed and many other purpose.









## Flat Bar Legs

 <p>SLC201-KA0325 (AF028C)</p>	 <p>CZ-LEG-001</p>	 <p>SLC301-H110</p>
 <p>SLC201-KA0326 (AF026-A)</p>	 <p>SLC201-KA0326 (AF026)</p>	 <p>GM-LEG-001</p>
 <p>LU-LEG-021</p>	 <p>YH-LEG-002</p>	 <p>LU-LEG-012</p>
 <p>YH-LEG-003</p>	 <p>LU-LEG-009</p>	 <p>SC-LEG-001</p>
 <p>CN-LEG-001</p>	 <p>DM-LEG-002</p>	 <p>IT-LEG-002</p>
 <p>TB-LEG-001</p>	 <p>SLC105-H100L120</p>	 <p>CN-LEG-002</p>

## Y Shape Legs

 <p>SLC104-H133L120</p>	 <p>CN-LEG-003</p>	 <p>SLC201-AC060</p>
 <p>SLC201-KA0151(AC005)</p>	 <p>SLC201-KA0486(AC009)</p>	 <p>YH-LEG-004</p>
 <p>YH-LEG-005</p>	 <p>LU-LEG-008</p>	 <p>SLC101-H50L115</p>

## Bullet Legs

 <p>SLC201-H38L150/180/381</p>	 <p>SLC201-H50L195</p>	 <p>SLC201A-D50L195</p>
 <p>CN-LEG-004</p>	 <p>SLC201-KA0383</p>	 <p>SLC201-KA0368-L150/L230</p>



# Sofa Leg Series II

We have a range of sofa legs to fulfill the requirement of various application. Our sofa legs are presently used in the making of sofas, bed and many other purpose.

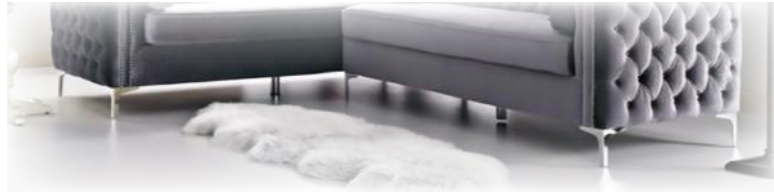

## Straight Legs

<p>LU-LEG-019</p>	<p>LU-LEG-007</p>	<p>LU-CTL101</p>
<p>SLC201-D50H127/ D50H127(4.5)/D50H152.4</p>	<p>SLA101-H90D38</p>	<p>CLB101-H100D38/50</p>

## Others

<p>SLC102-H120</p>	<p>SLC103-H100</p>	<p>CN-LEG-005</p>
<p>CN-LEG-006</p>	<p>CN-LEG-007</p>	<p>YH-LEG-001</p>

## Plinths

<p>SLC302-H110 300 (L) x 50 (W) x 110 (H)</p>	<p>YH-PLINTH-002 850 (L) x 60 (W) x 100 (H) x 6 (T)</p>	<p>ZK-PLINTH-001 20 x 40 x 978 (L) x 130 (H)</p>
---	---	--

## Plinths

<p>ZK-PLINTH-002 (A) 25 x 50 x 1920 (L) x 120 (H) (B) 25 x 50 x 1430 (L) x 120 (H) (C) 25 x 50 x 920 (L) x 120 (H)</p>	<p>ZK-PLINTH-003 (A) 1920 (L) x 35 (Ø) x 120 (H) (B) 1430 (L) x 35 (Ø) x 120 (H) (C) 920 (L) x 35 (Ø) x 120 (H)</p>	<p>ZK-PLINTH-004 1670 (L) x 40 (Ø) x 180 (H)</p>
<p>ZK-PLINTH-005 940 (L) x 40 (W) x 440 (H) x 6 (T)</p>	<p>ZK-PLINTH-006 770 (L) x 25 (Ø) x 150 (H)</p>	<p>ZK-PLINTH-007 1000 (L) x 32 (Ø) x 100 (H)</p>
<p>MQ-PLINTH-001 780 (L) x 50 (W) x 200 (H)</p>	<p>MQ-PLINTH-002 300 (L) x 150 (H)</p>	<p>MQ-PLINTH-003 740 (L) x 100 (W) x 150 (H)</p>

